

Paper 2004-24 Structural Design of Mooring Mast for Remotely Controlled Airship
Sagar M. Kale¹ and Rajkumar S. Pant²

¹ Project Engineer, Aerospace Engineering Department, IIT Bombay, Mumbai

² Associate Professor, Aerospace Engineering Department, IIT Bombay, Mumbai
sagar@aero.iitb.ac.in
rkpant@aero.iitb.ac.in

Abstract:

This paper presents the structural details of a non-guyed telescopic mast for a remotely controlled airship, which has been designed, fabricated and flight tested as part of the ongoing Program on Airship Design & Development (PADD) at IIT Bombay. The mast can accommodate non-rigid airships of length ranging from 3 to 6 m, and consists of three telescopic modules made of standard aluminum sections, mounted on a tripod base with castor wheels. The various modules and components of the mast were designed to enable quick assembly and transportation in a box that can be stowed below a railway sleeper berth. The mast's airship mounting unit incorporates a drag measuring device and an alerting system when the air loads exceed safe limits. The paper discusses the user-specified requirements, and the structural considerations that affected the design of the mast. The details of the various sub-assemblies of the mast and the reasoning behind the selection of their structural configuration are also presented.

Introduction:

The difficulties encountered in the design, construction and operation of a vehicle are, in general, directly related to its fundamental concept. A review of airship operations worldwide indicates that the main problems encountered are related to their ground handling and mooring [1]. The dependence of the airship on aerostatic lift confers upon it the possibility of vertical take off and landing; also gives rise to ground handling problems. In order to have a useful lifting capacity, it is inevitable that the airships possess a large gas volume, which implies a large surface area of the envelope. However, this makes them very sensitive to atmospherically derived forces, whether arising from discreet gusts or random turbulence. Mooring masts are therefore required for safe ground handling and anchorage of airships while not in use, and are a very important component of an airship system. A typical mobile tripod mast is shown in Fig. 1.

The essential requirement of a mooring system is that it must be capable of making the craft secure under all anticipated weather conditions, without imposing unacceptably high loads on the structure. Airship operations are also simplified if the mooring device can also be used to relocate it physically. These requirements prove to be the central

considerations, both in terms of the techniques adopted for mooring and in the determination of its structural strength requirements of the mast. The logic of restraining the airship (multi point mooring) to overcome atmospheric gusts and turbulence is likely to introduce large loads at the restraining attachments. In single point mooring, the airship is constrained only at its nose and is allowed to yaw and pitch about this point. Such a mast enables limited three

axes rotational /oscillatory freedom to the airship in the moored condition, which substantially reduces the structural loads due to atmospheric gusts.

Design Criteria For The Mast:

A remotely controlled airship has been designed, developed and flight tested at IIT, Bombay as part of the Program on Airship Design & Development (PADD). Details of this airship are given in [2].

Experience gained during the operation of this airship lead to the following requirements for a portable mast:

1. The total weight of the mast should be less than 50 kg.
2. The mast should be easily assembled within 20 minutes by 2 persons.
3. The mast height should be adjustable between 6 ft (min) to 10 ft (max).
4. The mast should provide +/- 30 deg freedom in pitch and 360 deg. in yaw to the envelope.

Conceptual Design Of Mooring Mast:

The following three types of configurations were possible for the mooring mast:

- Tripod mast with mechanized lifting using rack and pinion arrangement
- Collapsible mast using the lazy tong design
- Telescopic structure

Of these, the telescopic structure was selected to meet the portability requirement, since such a configuration could be compact and stable, if provided with proper interlocking to prevent vertical descent of the telescopic modules. A rectangular cross-section was chosen for the sub-modules for ease in fabrication, and non-guyed arrangement was chosen to ensure ease in assembly. The mast consists of three sub-assemblies, viz., the gimbal mechanism, a three module mast assembly and the bottom carriage assembly, as shown in Fig. 2. A drag measuring device is attached to the gimbal mechanism as an additional feature. Due to paucity of space, the details of load estimation, as well as the steps in detailed design are not being provided here. A description of the various sub-modules of the mast follows.

The Gimbal Mechanism

The gimbal mechanism as shown in Fig. 3 was designed to provide the required three axes motion to the airship while it is moored. This mechanism consists of a yawing pin, pitching pin, drag measurement and alerting device, rolling bolt, and nose hook latch. The yawing pin and pitching pin are made of aluminum, to allow free motion of the airship due to its low friction coefficient. They are designed to provide the desired freedom to the airship in yaw and pitch axes.

Drag Measurement And Alerting Device: To measure the drag force on the airship a spring-operated force-measuring device was designed, as shown Fig. 4. A pointer attached to the helical tension spring with the help of a slider block, slides over the scale to indicate the drag force. The maximum frontal drag on the airship at 80 kmph when its longitudinal axis is parallel to ground was estimated to be 60 N. But to enable the use of the same drag measuring device for bigger airships of the same class or to accommodate bigger airships and to measure larger drag due to odd conditions, it was decided to design the device to be capable of measuring drag force up to 100 N. The scale is calibrated such that the readings are visible from the ground level. A buzzer circuit is attached to the pointer, which gets activated if the pointer moves beyond a particular value (say 80 N), thus providing an aural

warning to the ground crew to move the airship and the mast inside the storage area, when the atmospheric conditions are not suitable for outdoor storage.

Rolling Bolt: The rolling bolt serves two purposes; it connects the drag measuring and alerting device to the nose hook assembly, and also provides 360 deg. freedom in roll to the airship.

Nose Hook Latch: The design of the nose hook latch is governed by the nose hook that is attached at the airship nose. The crucial component of the nose hook latch is its pin, whose diameter was matched to the nose hook hole diameter and the material used is SAE 1030. For simplicity, a standard M8 bolt was used for locking the airship nose hook with the latch.

Three Component Mast Assembly

The mast assembly has three modules, each consisting of an assembled rectangular structure of four aluminum hollow square pipes. Each module is 5 ft. in length, with an overlap of 1.5 ft. for stability. The first module supports the gimbal mechanism, the second module allows height adjustment, and the bottom module transfers all the loads to the carriage assembly as shown in the Fig. 4.

Bottom Carriage Assembly

The bottom carriage assembly comprises the strut members, mast legs, mast base and castor wheels. This assembly was designed for the maximum load condition. The mast undergoes bending under applied load conditions due to horizontal drag force on the structure as well as due to the airship drag. The drag/ aerodynamic forces on airship envelope, control surfaces and on the gondola were calculated for various wind directions. The maximum bending moments at mast base were calculated for the required maximum extended height of 10 ft, for a wind load of 80 kmph. For resisting these bending loads, various sections were checked for their suitability for the application. It was found that the wind load on the mast structure was many times higher than the drag force experienced by the airship. A brief description of the various components of the bottom carriage assembly follows.

Strut Members: It was required to design strut member in folded configuration to meet the requirement for quick assembly, and to result in a compact structure for ease in transportation. A rectangular section of steel was selected for the strut due to higher strength requirements and for satisfying the geometrical constraints in design and ease in attachment with the module 3 and mast legs. Details of strut member attachment is shown in the Fig. 5.

Mast Legs: Mast legs are the main load bearing members, since the horizontal load from gimbal mechanism (i.e. airship drag) and self weight of the mast acts on the mast legs, from where it gets transferred to the ground through castor wheels. The legs were designed and fixed to the mast base in such a way that they can be folded inside the mast, making the whole mast system compact for shipping and lead to reduced assembly time. The hollow rectangular section permits quick fitment with the mast base and the castor wheels. The length of the mast leg is 6 ft, which provides adequate ground stability.

Mast Base And Castor Wheels: As shown in Fig. 7, the entire mast assembly is mounted on a base which is made of aluminum angle sections; bolts were chosen as a mean for locking rather than other options like riveting to ensure room for adjusting the tightness and rigidity of joints. The mast legs are bolted to the mast base using two bolts, the inner bolt has to be removed while folding the leg inside the mast; and bolted on while assembly.

Castor Wheel Assembly: A standard castor wheel with 150 kg load bearing capacity was selected for this application, which results in sufficient factor of safety. The dimensions and other details are given in Fig. 6 and Fig. 7 shows the attachment of strut member to the mast leg and castor wheel. The castor wheel is spring loaded to enable self-alignment of the mast assembly on uneven terrains and to keep it stable. The spring is mounted on a bolt, which slides inside the hole provided in the mast leg as shown in the Fig. 10.

Results And Conclusions:

The total weight of the three modules was estimated as 35 kg, which is well within the upper limit of 50 kg. The configuration for the various modules ensures that it can be assembled within a short time by a two-member team. The use of telescopic modules with adjustable lengths ensure that the height requirements from the mast can be met. Desired pitch and yaw freedom is available through the gimbal mechanism. Thus, it can be said that this non-guyed telescopic mast designed for the remotely controlled airship met all the user specified requirements.

However, a critical analysis of the configuration revealed that many improvements to this basic design could be incorporated. First of all, the cross members in the three component mast assembly could be diagonal instead of horizontal strips, as in the present case. In the bottom carriage assembly, the mast legs could be hinged to the mast base (instead of being bolted, as in the present case), to enable quick folding and hence reducing the effort and time required for dis-assembly. Further, the springs in the castor-wheel assembly may not suffice for providing alignment on uneven ground. For improved portability, it may be better to transport the dis-assembled mast in two boxes; one containing the gimbal mechanism and three component mast assembly, and the other containing the bottom carriage assembly and the tools. The mast base could be of MS, to ensure sufficient strength for withstanding the total loads expected. Rollers could be provided in module 2 and 3 of the three component mast assembly, to ensure ease in adjusting the height of the mast.

References

- [1] Khoury G. A., and Gillett, J. D., Eds., *Airship Technology*, Cambridge Aerospace Series: 10, ISBN 0521 430 747, Cambridge University Press, 1999.
- [2] Pant, Rajkumar S. and Gawale, A. C., *Design, Fabrication and Flight Testing of a Remotely Controlled Airship*, National Conference on LTA Technologies, ADRDE, Agra, October 2002.



Fig 1: Mobile Tripod mast for Goodyear Blimp

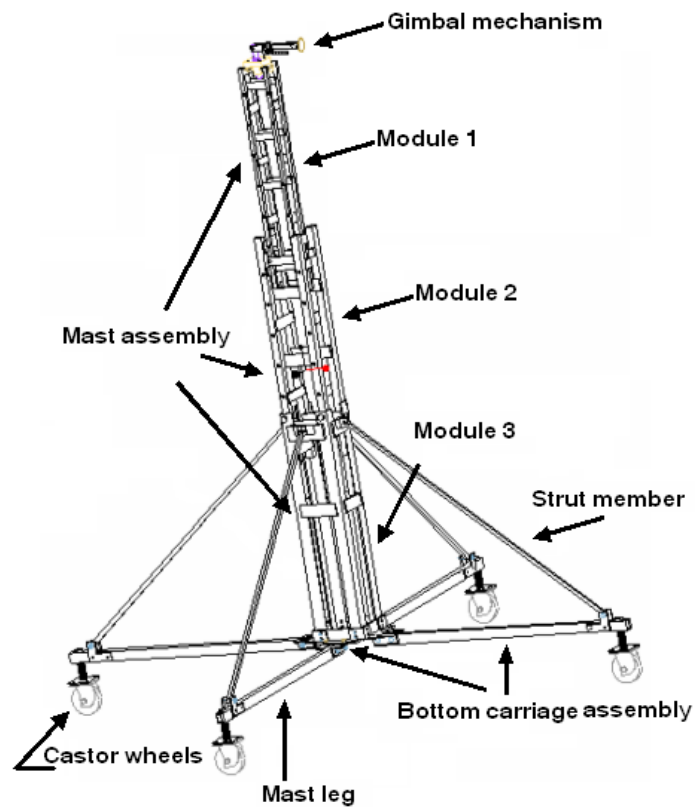

Fig. 2: Schematic view of the non guyed telescopic mast

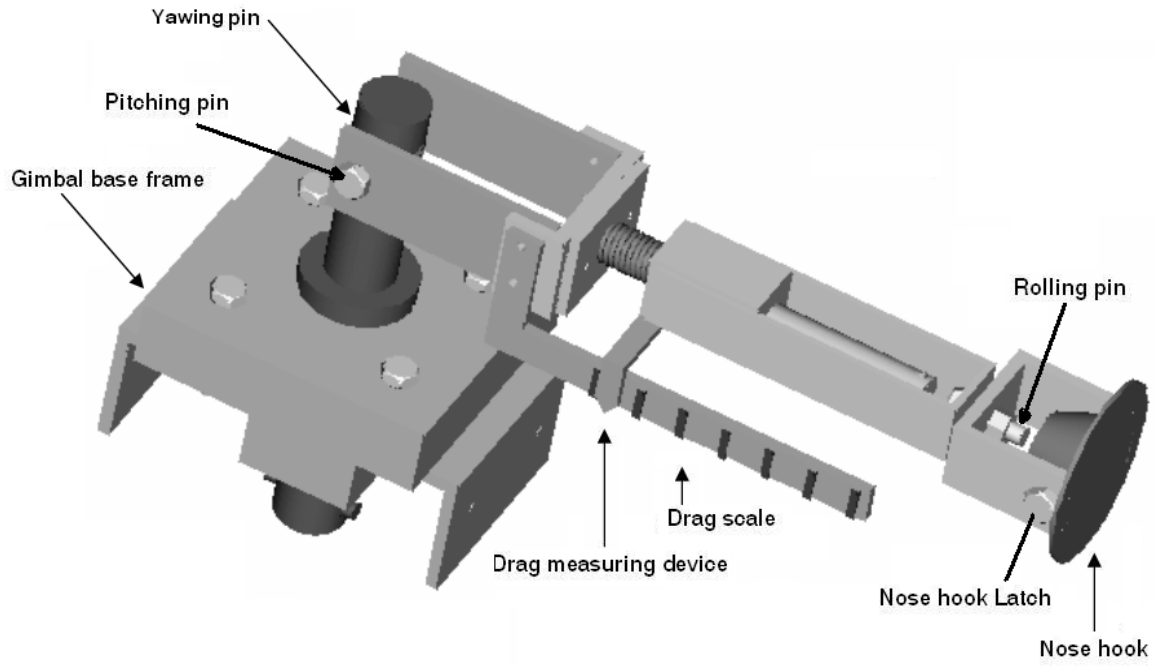

Fig. 3: Gimbal mechanism with different components

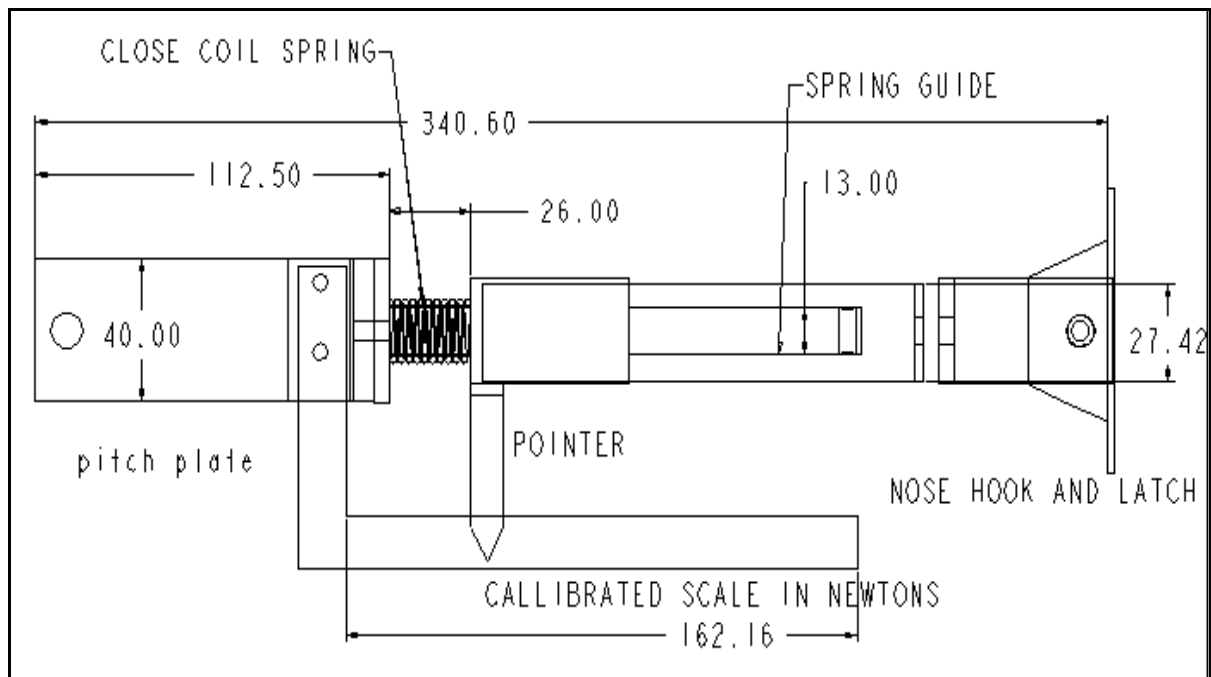
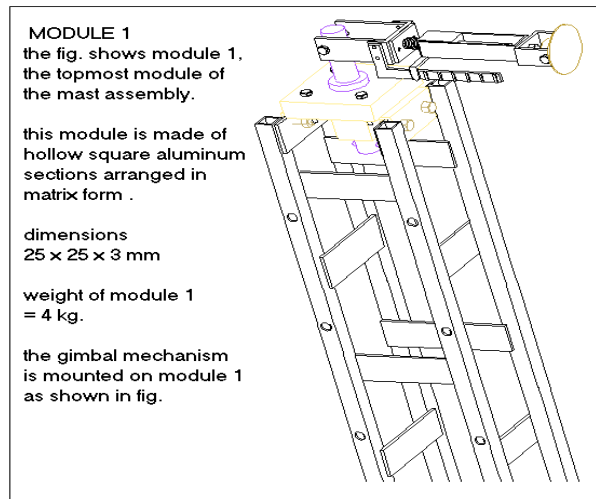
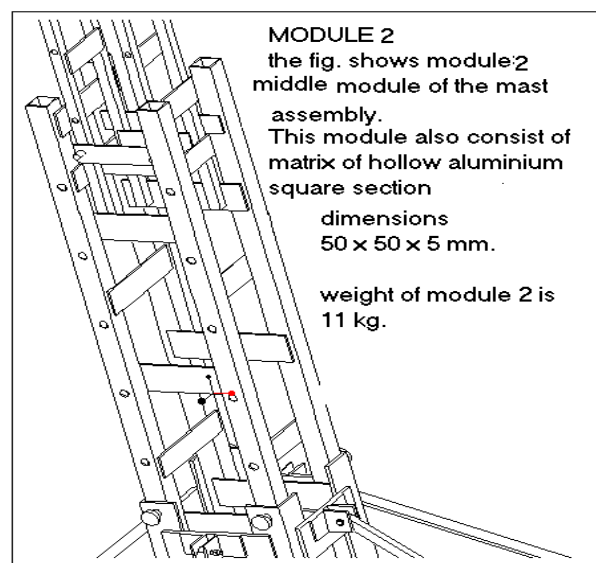

Fig. 3: Detailed drawing of the Drag Measuring and Alerting Device



Module 1 with Gimbal mechanism



Module 2

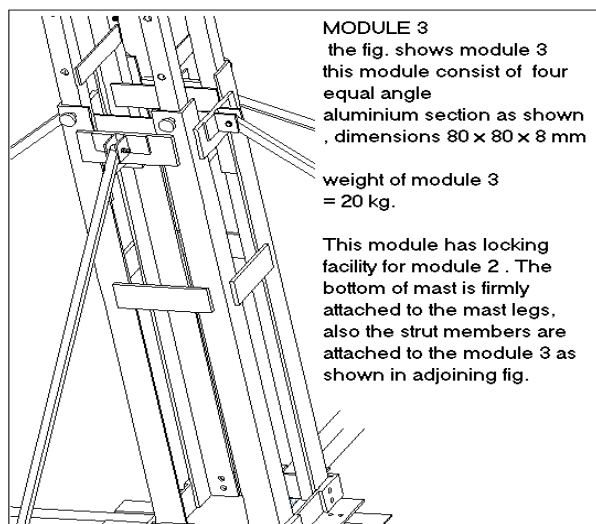

Module 3 with struts attached

Fig. 4: The three component mast assembly

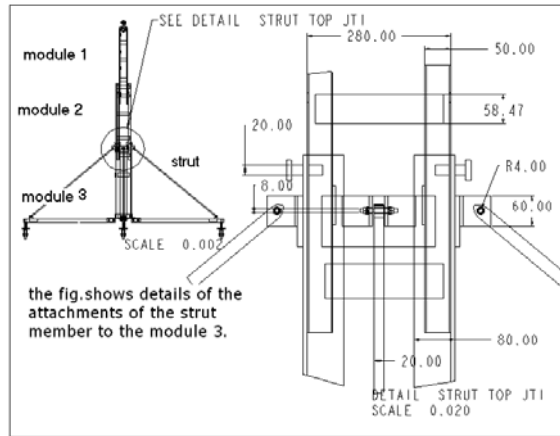

Fig. 5: Dimensional details of strut attachment

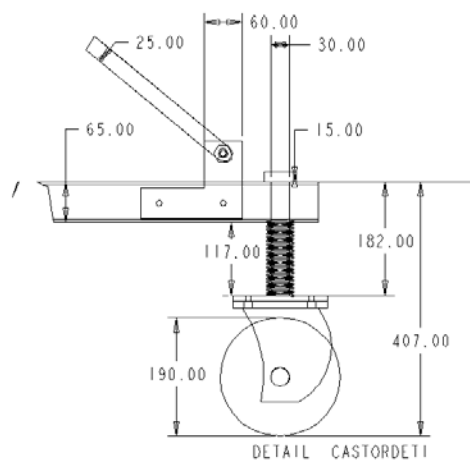

Fig.6: Details of castor wheel attachment

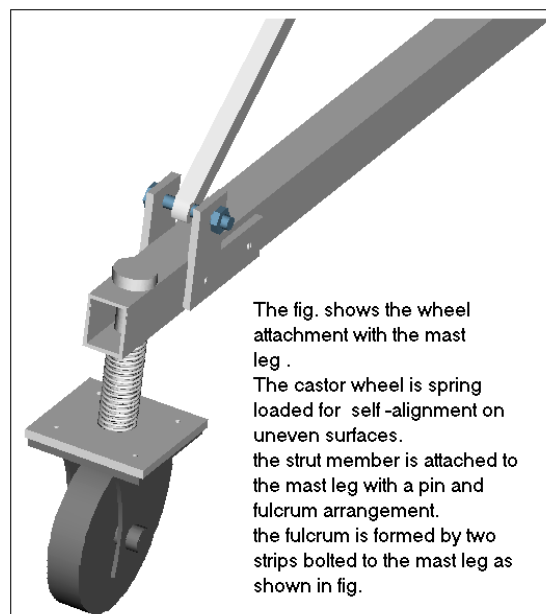

Fig.7: Spring mounted bolt for the castor wheel

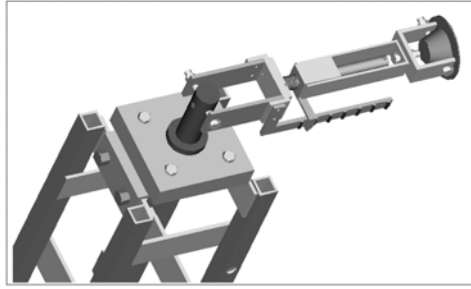

Fig. 8: Gimbal mechanism attached to module 1

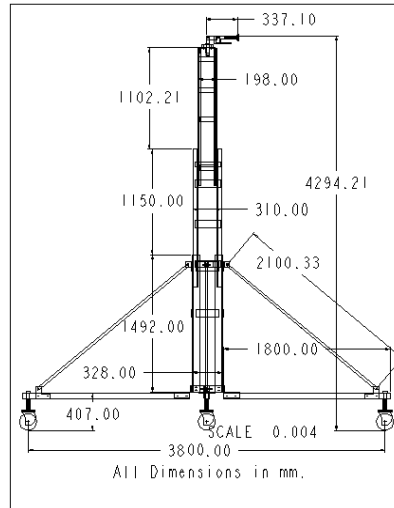

Fig. 9: Dimensional details of the mast